

FEIGHNER VERTICAL STYLE LIFT

OWNER AND OPERATIONS MANUAL

Model 6,000/ maximum load of 6,000 pounds

Model 7,000/ maximum load of 7,000 pounds

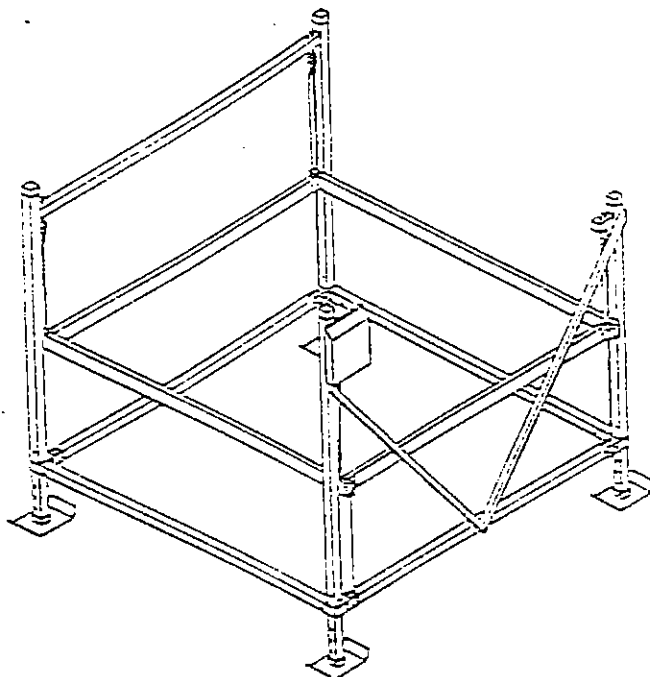

**Manufactured by & for:
The Feighner Company, Inc.
6620 E. M-79 Highway
Nashville, MI 49073-9717
Phone (517) 852-0959
Fax (517) 852-0961**

TABLE OF CONTENTS

<u>PAGE</u>	<u>SECTION</u>
3	Introduction
3	Warnings and Safety
4 - 5	Parts List
6 - 13	Assembly Lift
14 - 15	Installation
16 - 18	Operation -Loading, Raising, Lowering
19	Removal and Storage
20	Service
21	Cable Routing Drawing
22	Electric Power Unit Safety & Warnings

INTRODUCTION

Feighner vertical lifts will lift your boat up and out of the water for dockside storage. These lifts are designed to rest on a stable lake bottom. This lift performs well in low water conditions, fluctuating water up to four feet or when your boat requires mooring high out of the water. There are maximum allowable water depths depending on your leg lengths and situation. A properly positioned lift will provide safe, convenient, quick mooring for your boat.

The lift functions by turning the lift hand wheel clockwise to raise the lift. Properly position your boat in the lift and it will raise with the lift rack. The wheel is turned counterclockwise to lower the lift.

Information in this manual is not all inclusive and cannot cover all unique situations. If you have questions about assembly, installation, operation or suitability of this product contact an authorized Feighner dealer or The Feighner Company, Inc., at (517)852-0959.

WARNINGS AND SAFETY

Your SAFETY is the most important issue related to this product. It is critical that all assemblers, installers and users read and fully understand the warnings and safety information contained throughout this manual before using this product.

Safety Instructions

Never exceed recommended weight capacity of your lift. The weight of your boat includes the hull, engine, fuel, gear, battery, and added accessories. The dry weight reported by the manufacturer usually includes only basic boat and engine. The boat manufacturers reported weights can be understated by 10 -30%! This is before you add fuel, fluids, batteries, accessories, etc.! Weigh your boat at a certified scale to be absolutely sure of the total weight. You will be lifting 20 - 50% more than the reported dry weight when everything is considered.

- A properly educated or trained person is needed for assembly and installation of this product.
- Wear proper protective clothing and eye wear when assembling or installing lift.
- Do not assemble, install or use this product if items are missing or damaged.

■ **WARNING - Stay clear of lift (facing wheel) while operating. Do not allow anyone on, in or under lift. A cable or lift part failure can cause a sudden drop of boat, resulting in a crushing or falling injury or death!**

- Do not allow people on boat when boat is on lift in raised position.
- Do not make alterations or adjustments to lift or accessories when boat is on lift.
- Check cables for frays, corrosion or breaks at least once a month. A cable breaking while boat is in lift could damage boat or lift. Severe bodily injury could also occur.

PARTS LIST

Before assembly, identify each part. Remove parts from boxes, bags and bundles. Mark each item with the proper part letter (indicated in the left-hand column). This will confirm that all parts are here before beginning assembly and allow you to easily follow the assembly instructions.

Bolt Bag

24 - 1/2" x 5 1/2" Hex Bolts
2 - 1/2" x 5" Hex Bolts
4 - 1/2" x 4 1/2" Hex Bolts
4 - 1/2" x 4" Hex Bolts
12 - 1/2" x 3 1/2" Hex Bolts
1 - 3/8" x 8" Hex Bolt
46 - 1/2" Nuts
5 - 1/2" Lock Nuts
1 - 3/8" Nut
68 - 1/2" Washers
2 - 3/8" Washers
12 - 1 7/8" Round Spacer Tube
1 - 1 5/8" Round Spacer Tube
2 - Cable Collar
4 - Zerks

Hardware Box

4 - Caps
1 - Hefty Hoist EPU
1 - Adapter Sleeve
1 - Grease
1 - Motor Pulley 2" x 3/4"
1 - Belt A-36
1 - Hub 4" wide, 3" dia.

Motor Hardware Box

1 - Cover
1 - Cover Hardware
1 - Motor, w/attached switch and cord

Part G
Rear Rack
W/2 Cables
Qty 1

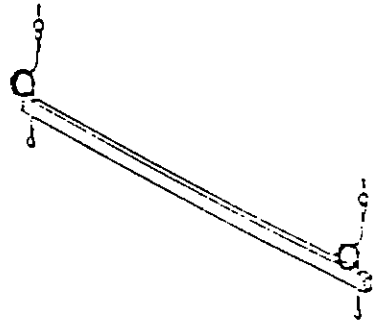

Part H
Front Rack
W/1 Cable
Qty 1

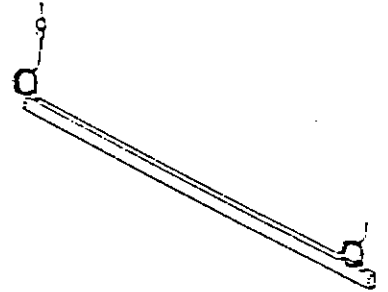

Part A
V Side
Qty 1

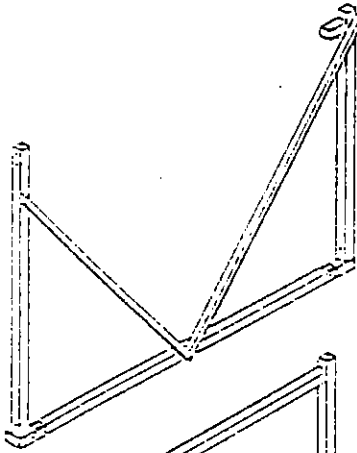

Part B
Reg. Side
Qty 1

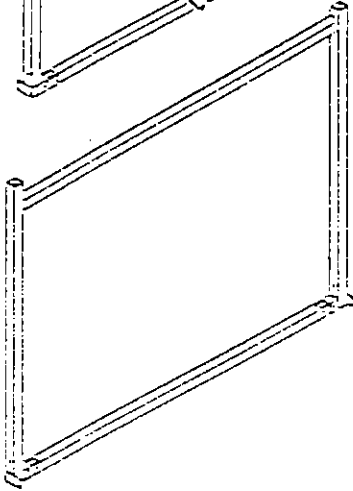

Part C
Leg
Qty 4



Part J
Leg Pad
Qty 4



Part D
Bottom Beam
Qty 2

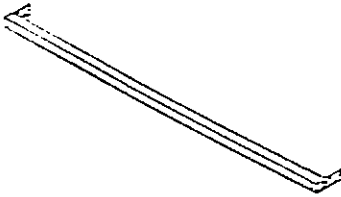

Part E
Left Rack
W/Cables
Qty 1

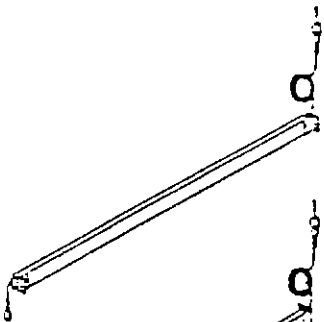

Part F
Right Rack
W/Cables
Qty 1

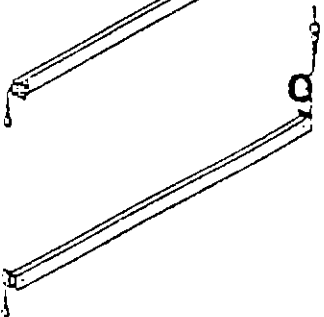

****Fully read and understand each step before proceeding with that step.**
****Only hand tighten bolts and nuts until lift is completely assembled.**

#1 Slide #9 Blue Caps on uprights as shown.

#2 Insert all (4) C parts (legs) into J parts (foot pads), secure using $\frac{1}{2}$ " x 4" hex bolts and $\frac{1}{2}$ " nuts. Insert (4) C parts (legs) into part A (v-side) and part B (opposite side) as shown. Use (1) $\frac{1}{2}$ " x $4\frac{1}{2}$ " hex bolt, (2) $\frac{1}{2}$ " washers & (1) $\frac{1}{2}$ " nut to attach each leg.

#3 Place A part (v-side) and B part (opposite side) about ten feet apart as shown. Attach one D part (bottom beam) to *front* of A & B parts as shown. Attach with (10) $\frac{1}{2}$ " x $5\frac{1}{2}$ " hex bolts with (10) $\frac{1}{2}$ " nuts and (20) $\frac{1}{2}$ " washers.

Note: Bolt only 5 of the 6 holes at each corner at this time. The remaining hole will be used in a later step. See drawing for the one connection hole (in each front corner) not used at this time.

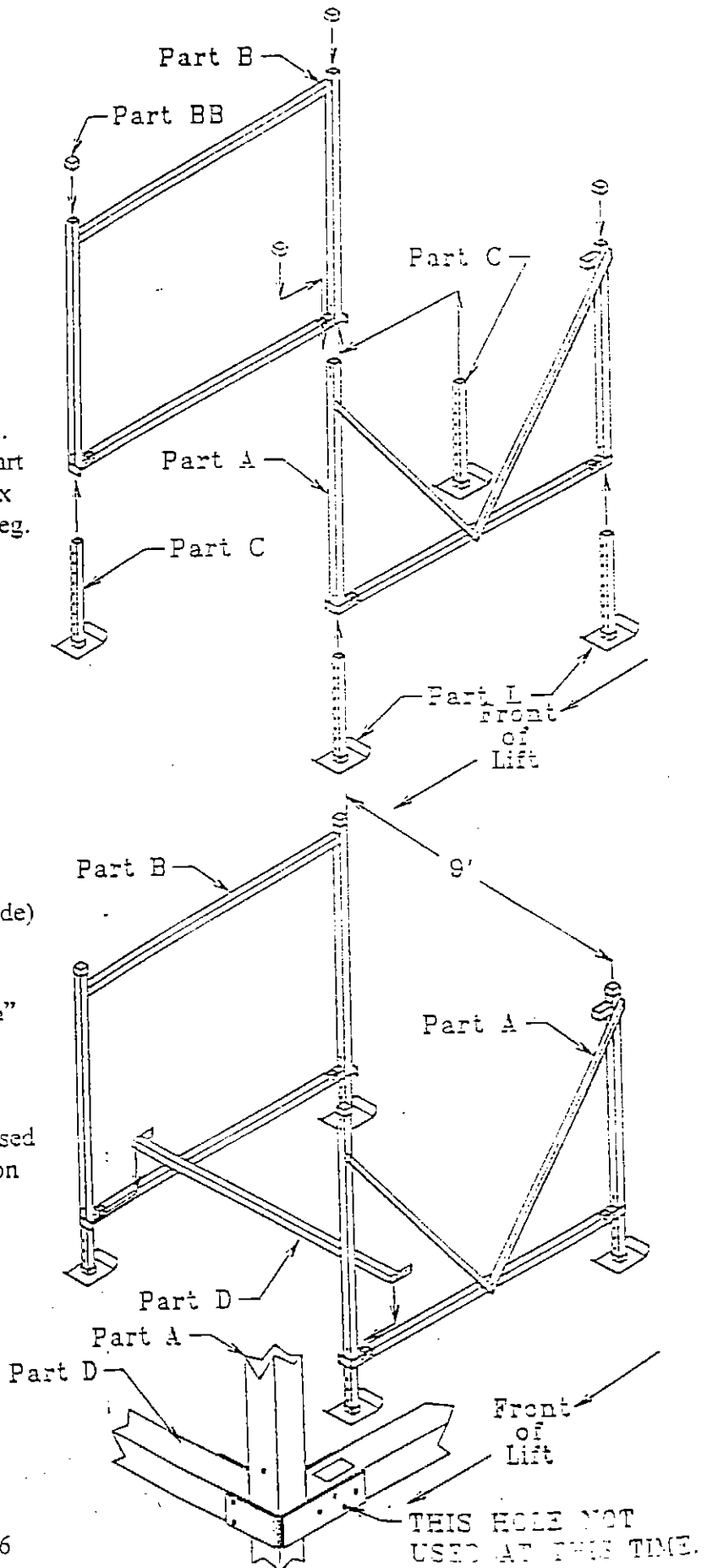

#4 Attach one D part (bottom beam) to rear of A & B parts as shown. Attach with (10) $\frac{1}{2}$ " x $5\frac{1}{2}$ " hex bolts, (10) $\frac{1}{2}$ " nuts and (20) $\frac{1}{2}$ " washers at each end.

Note: Bolt only 5 of the 6 holes at each corner at this time. The remaining hole will be used in a later step. See drawing for the one connection hole (in each rear corner) not used at this time.

Note: The holes not used (in each rear corner) are different than those in last step. See drawing.

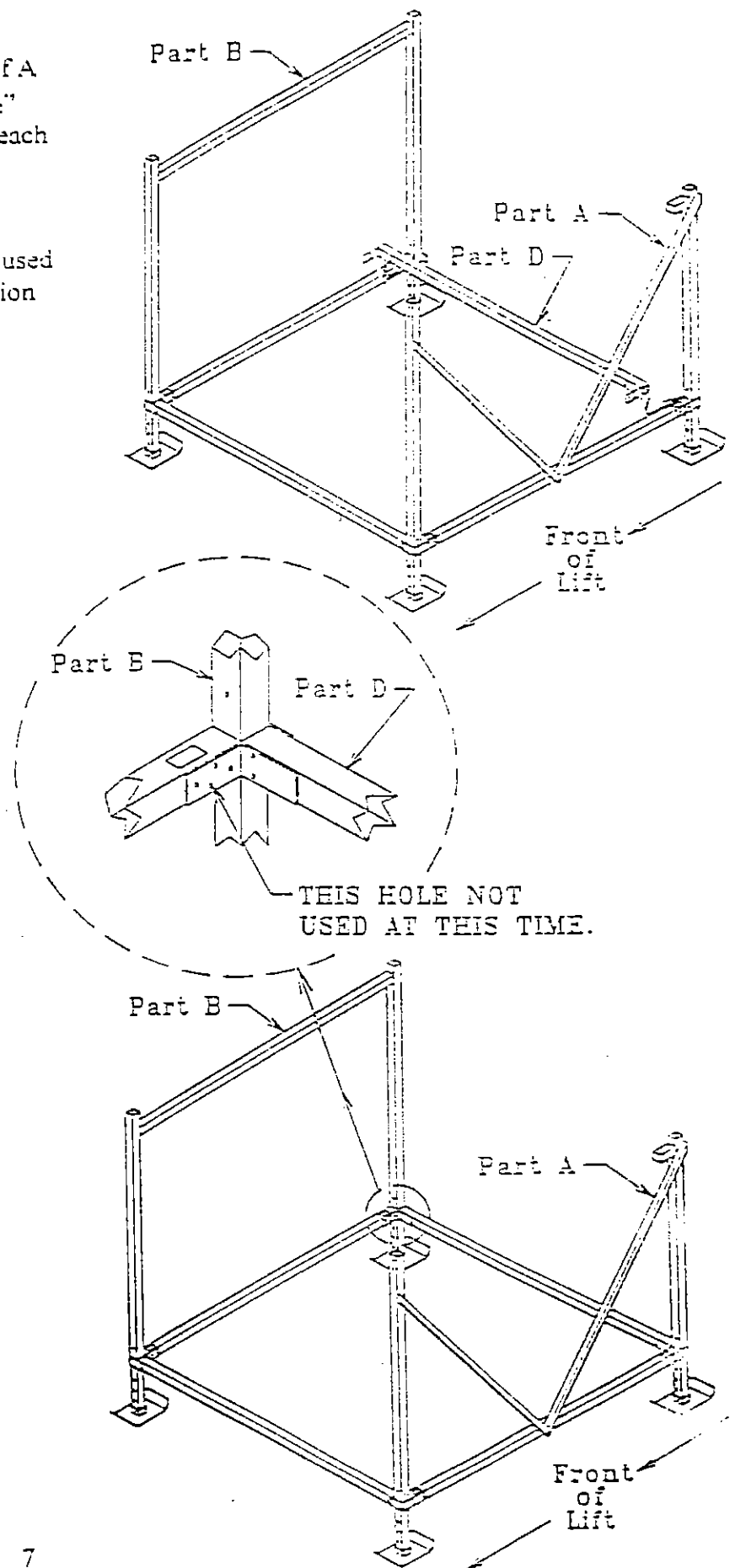

#5 Set part E (left rackside) in area shown. Place end with cable loop into position. Secure cable loop using open hole in part A (V-side) with $\frac{1}{2}$ " x $5\frac{1}{2}$ " hex bolt, $\frac{1}{2}$ " nut & (2) $\frac{1}{2}$ " washers.

Note: This completes the connection process in that corner for part A and part D (bottom beam).

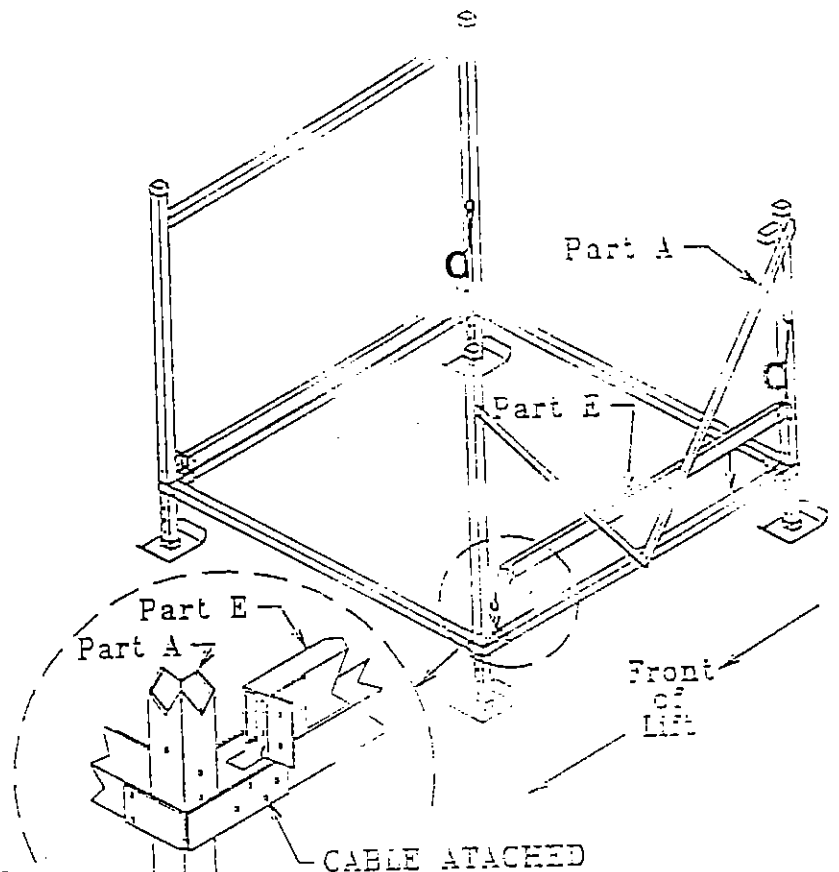

#6 Set part F (right rackside) in area shown. Place end with cable loop into position. Secure cable loop using open hole in part B (opposite side) with $\frac{1}{2}$ " x $5\frac{1}{2}$ " hex bolt, $\frac{1}{2}$ " nut & (2) $\frac{1}{2}$ " washers.

Note: This completes the connection process in that corner for part B and part D (bottom beam).

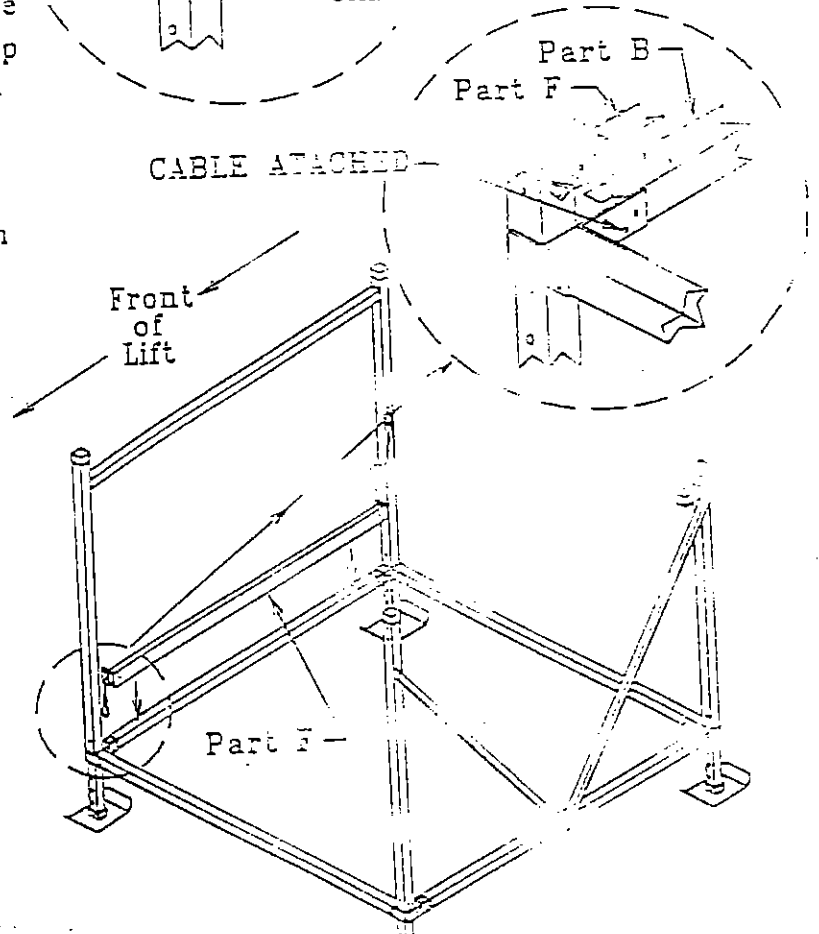

#7 Set part G (rear rackbeam) in area shown. This part has two cables contained within. Place each cable loop into position as shown.

-Secure one cable loop using open hole in part A (V-side) and opposite cable loop in open hole in part B (opposite side). Use (2) 1/2" x 5 1/2", (2) 1/2" nuts & (4) 1/2" washers.

Note: This completes the connection process in this corner for part A and part D (bottom beam).

Note: This completes the connection process in this corner for part B and part D (bottom beam).

#8 Attach part G (rear rack beam) to part E & F (rack sides). Use (3) 1/2" x 3 1/2" hex bolts, (3) 1/2" nuts & (2) 1/2" washers and (3) 1 7/8" round spacer tubes at each end. Spacer tubes go inside G part & bolts go through them.

Note: Center bolt does not get a washer.

#9 Place part H (front rackbeam) in area as shown. Attach part H to part E & F (rack sides). Use (3) 1/2" x 3 1/2" hex bolt, (3) 1/2" nuts, (6) 1/2" washers and (3) 1 7/8" round spacer tubes at each end. Spacer tubes go inside H part and bolts go through them.

Note: Center bolt does not get a washer.

#10 Attach the I-bolts with cables to the proper holes in your part A & B sides as shown. Slide I-bolt into position. Attach a 1/2" lock nut and washer, located in bolt bag, to each I-bolt.

Note: Be sure washer is in place and that lock nut is tightened so at least 1/4" of I-bolt thread is exposed.

Note: There are five I-bolts to attach. See the drawing of I-bolts and cables on next page to ensure correct location.

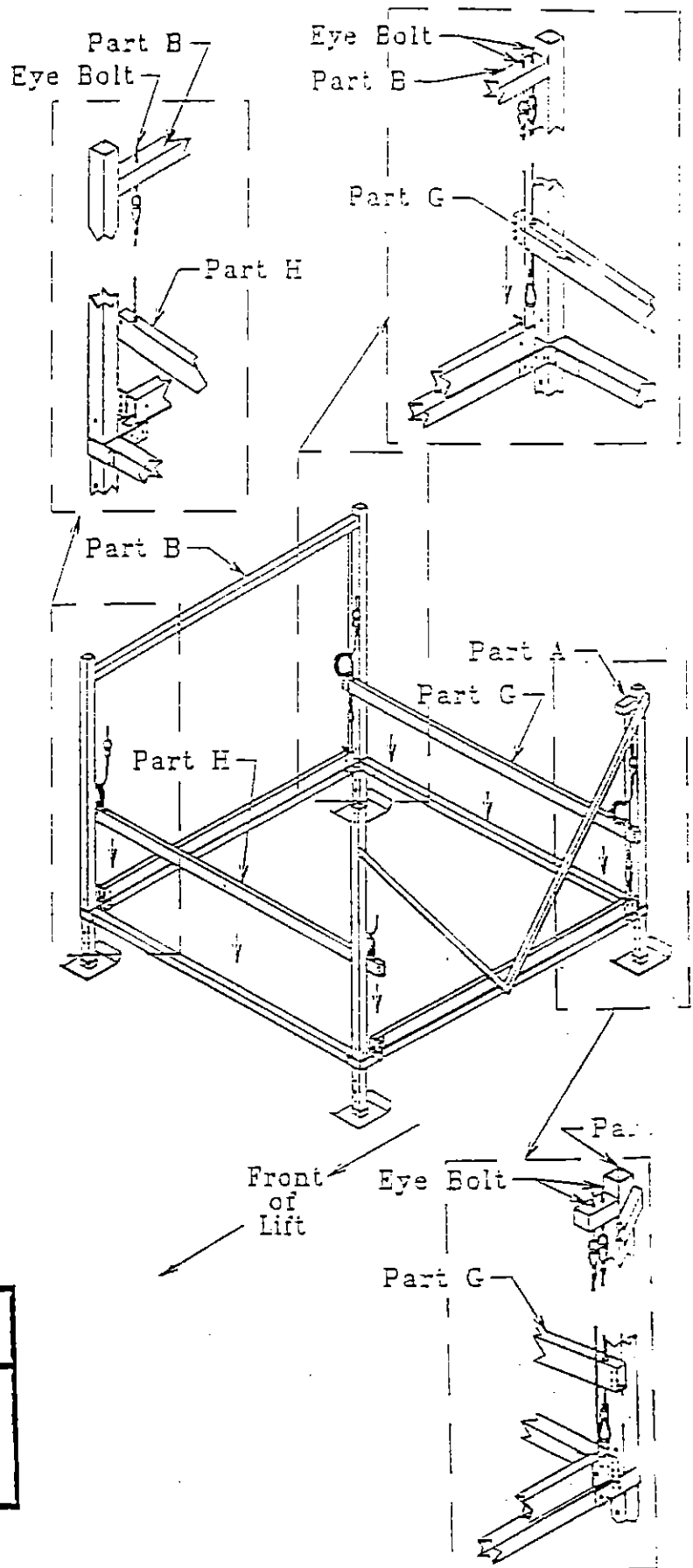

CAUTION

Failure to attach cables, I-bolts, washers and lock nuts correctly could result in a severe crushing, cutting or pinching injury. Severe damage to lift or boat could also occur.

Assembly Showing proper cable location

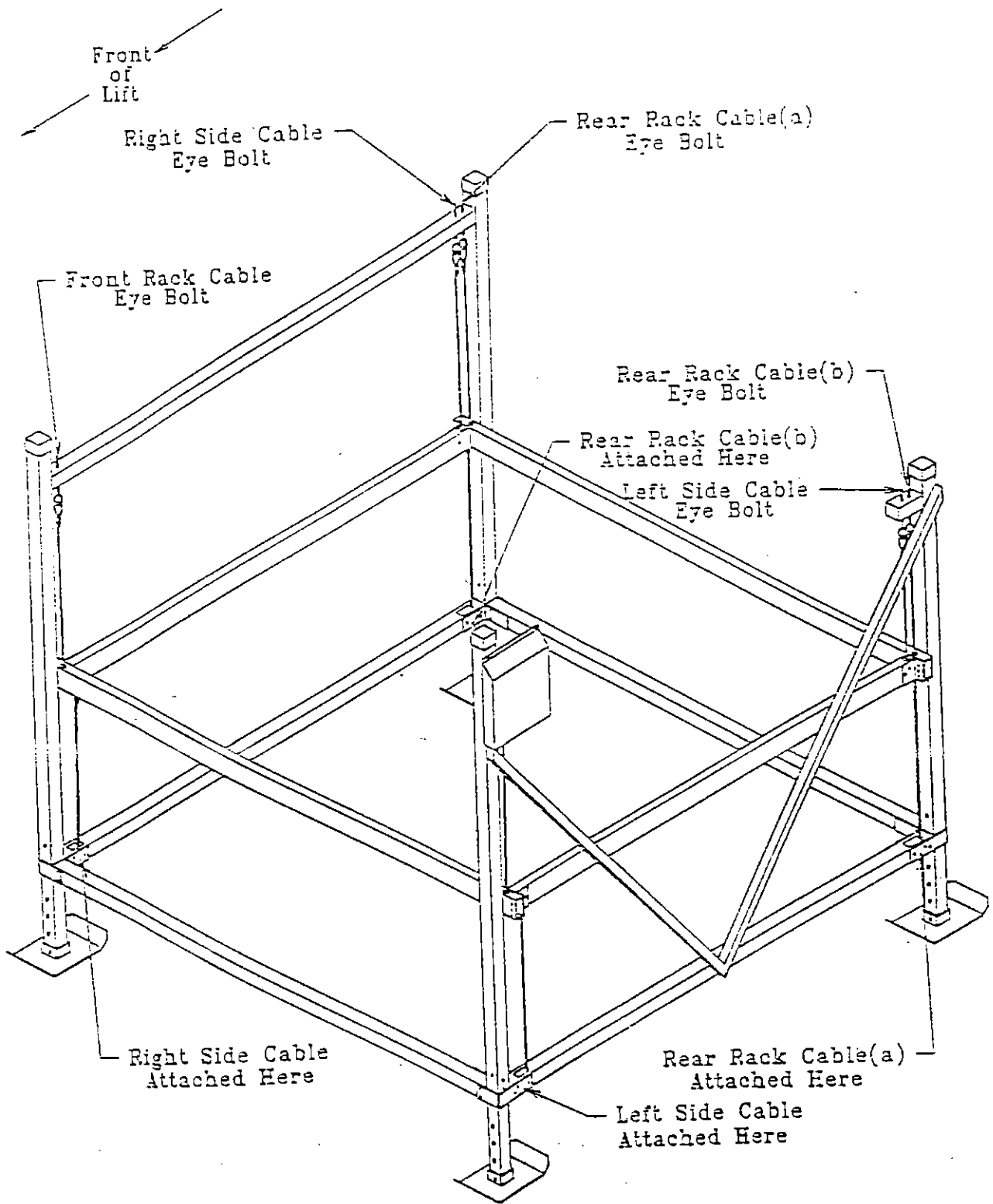

WORM DRIVE WINCH INSTRUCTIONS & SAFETY TIPS

STEP 1 - Bolt the drive drum to the lift side that has the extended upright. This is only place where the winch can be attached to the lift. Use (2) ½" x 5" hex bolts, (2) ½" nuts & (4) ½" washers.

Note - Make sure the drive drum is extending toward the outside of the lift.

STEP 2 - Slide the plate that has the worm drive unit on it onto the drive drum and bolt in place using (1) 3/8" x 8" bolt, 3/8" nut & (2) 3/8" washers. When securing the bottom of the plate to upright, use (1) 1 5/8" aluminum spacer between the plate and the lift upright.

STEP 3 - Bolt the motor to the plate with the worm drive unit. Make sure the motor drive shaft is facing the same way as the drive shaft unit. Use the (4) 3/8" x 1" bolts, (4) 3/8" lock washers & (4) 3/8" nuts that are located on the plate.

Note - Do not completely tighten down the motor at this time. Leave the motor loose so you can get the belt on the pulleys.

STEP 4 - Put the large pulley on the worm drive unit drive shaft and the small pulley on the motor drive shaft. Before tightening the pulleys in place with the setscrews, make sure the large pulley is directly above the small pulley. Once the pulleys are in line, tighten them in place. Use Allen wrench located on the plate to tighten setscrews.

STEP 5 - Put the belt over the large and small pulleys. Tighten the belt by adjusting the motor until the belt is snugly in place. Then tighten the motor in place.

STEP 6 - Switch Box must be mounted in upright position to the side of white EPU cover. Using pre-drilled holes, attach with ¼" x 1" machine bolts, ¼" washers and ¼" nuts.

STEP 7 - Clip the winch cover in place.

STEP 8 - Attach the cable to the drive drum by sliding the cable through the hole in the drive drum far enough so the cable sticks out from the inside of the drum. Then slide the little collar with setscrews over the end of the cable so the collar is about 1" down on the cable and tighten in place using the setscrews. Then pull the cable back through the drive drum until the collar is firm against the inside wall of the drive drum.

****The Feighner Company, Inc. recommends that an electrician does the installation and hook-up of this electric winch.**

FOR WARRANTY TO GO INTO EFFECT !!!

An electrician to be certain that the proper amount of current is reaching the electric motor during all phases of operation must check the electric motor under a full load.

THE FEIGNER COMPANY, INC. IS NOT LIABLE FOR ANY INJURY INCLUDING BUT NO LIMITED TO IMPROPER INSTALLATION, FAULTY WIRING, AND OR IMPROPER USE.

CAUTION

Be sure cable wraps tight and uniformly on hub.
Do not allow cable to wind up loosely on hub.
Cables wrapping incorrectly will result in rapid cable wear.

#11 Thread excess cable onto motor hub by turning motor spool clockwise at this time. Applying tension to cable, by holding it tight when raising lift, will help to develop proper wrap.

CAUTION

Use a leather glove or other hand protection to avoid cuts when applying cable pressure.

#12 Proper Cable Adjustment

a) There are four cables with I-bolts and nuts that must be adjusted to properly level cables. These I-bolts are all located near the rear uprights as shown.

b) Turn motor spool so front rack beam raises about 6" above the bottom of frame. Adjust cables so all corners of rack are the same distance from frame.

Note: The nuts on I-bolts require adjustment to level your lift rack. Use the frame below the rack as your reference point. Measure the distance from frame to rack in each corner. These distances should all be within a 1/4" inch.

Note: Be sure washer is in place and that lock nut is tightened so at least 1/4" of I-bolt thread is exposed.

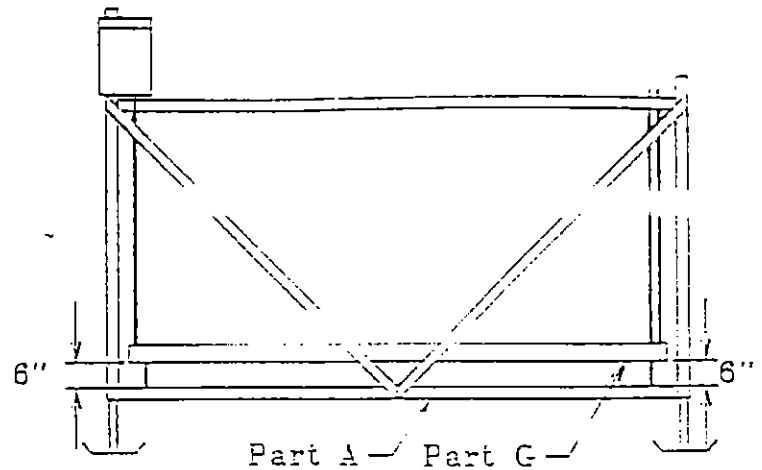

SIDE VIEW

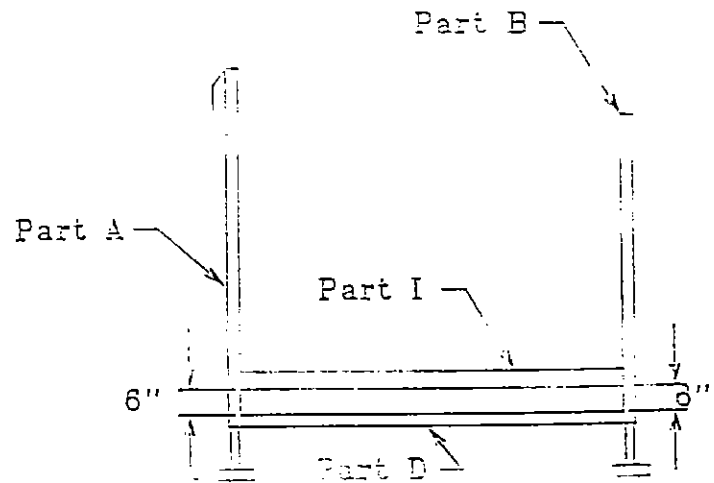

REAR VIEW

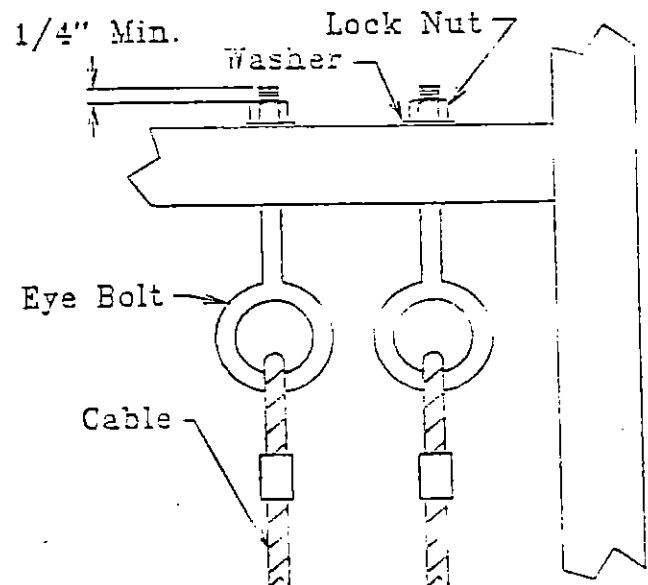

#13 Firmly secure all bolts and nuts at this time.

#14 Many accessories are available for use with this boat lift. See assembly instructions for each required accessory. Follow relevant safety instructions mentioned in this manual when attaching accessories.

INSTALLATION

The following are guidelines or suggestions for installation. Situations vary between installation sites. Common sense may dictate that other factors be considered in your situation. Your site may not allow for some of our suggestions to be used or followed entirely. Do not, under any circumstances, endanger yourself or risk damage to lift or boat when installing.

CAUTION

If you are unable to properly and safely install this boat lift, please have a trained boat lift installer perform the installation.

#1 Measure water depth of exact position you want to locate lift.

#2 Before installing, adjust lift legs so lift can be properly positioned in water.

Note: Lift must be positioned low enough so boat can float into position before raising, while also allowing high enough position so the boat can be fully raised up and out of water.

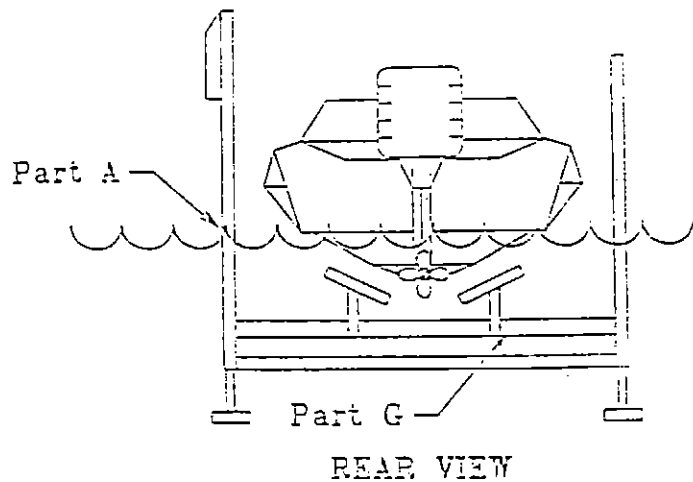

#3 Be sure lift rack is in fully lowered position. This will prevent rack from shifting when moving lift into position.

Note: Lift rack must always be in partially raised position before any weight is applied. Adjust lift legs down or move lift to deeper water if this cannot be accomplished!!!

CAUTION

Never apply weight on lift when top rack is in fully lowered position. Doing this will bend lift frame and cause permanent damage to lift.

CAUTION

A raised lift rack could cause a pinching or cutting injury during installation. Be sure lift rack is fully lowered when installing. Never move or carry your boat lift by grabbing the lift rack.

#4 Carry, lift, roll, float or slide lift into position. Position alongside dock, so motor can be easily turned from on dock.

CAUTION

Lift must be resting on lake bottom in a level, secure and stable position for safe operation. An unstable lift installation could result in tipping of lift during operation, causing damage to watercraft, and crushing or pinching injury to operator.

OPERATION

-Loading of Watercraft-

#1 Be sure lift rack and cradles or bunks are positioned below water surface so they will not interfere with boat floating into position.

CAUTION

Be sure boat is properly balanced and centered on lift before raising.

CAUTION

If lift is without a boat in it for more than one day, raise the rack (pulleys) fully out of the water to help prevent corrosion of these parts.

#2 Position boat with center of gravity near middle of lift. For most rear engine mounted boats, this requires you to position the boat mostly forward in the lift.

WARRANTY DOES NOT
APPLY IF DAMAGE IS
CAUSED BY IMPROPER
LOADING!!

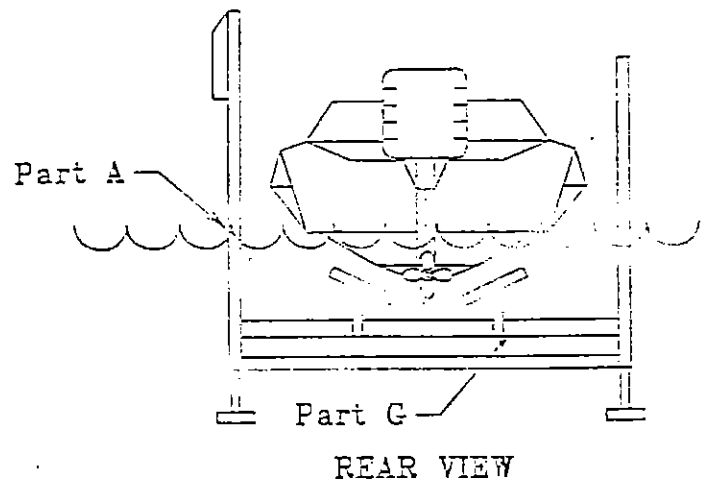

-Raising Lift-

#1 Make sure craft is in proper position. Turn motor spool clockwise. Stop turning motor when boat reaches desired height out of the water.

WARNING

Stay clear of lifts (facing motor) while operating. Do not allow anyone on, in or under lift. A cable or lift part failure can cause a sudden drop of boat, resulting in a crushing or falling injury or death!

CAUTION

Turn motor spool (clockwise) to raise lift. Wrapping cable in wrong direction could cause fast spin down of motor spool.

CAUTION

If fast spin down of motor occurs do not touch motor or attempt to stop.

CAUTION

Properly cover your boat, when in raised position, if rain can gather in your craft. An inch of rain adds several pounds to lift. Added weight may result in boat being over capacity.

CAUTION

Do not over raise lift rack. Stop before top of rack hits cable loops attached to I-bolts. Over raising could cause damage to motor, cables or other parts.

CAUTION

Do not allow people on boat when in a raised position on lift. Entering boat when in the raised position adds to lift load and is not safe! A falling injury could occur should lift fail.

CAUTION

Do not allow anyone who is in the water within six feet of the lift. A crushing injury could occur to swimmer should cable, motor brake or lift part fail.

-Lowering Lift-

#1 Turn motor counterclockwise.

Note: Turn motor down one or two turns past point when craft begins to float (This must always be at some point before lift rack is contacting bottom beams). Then turn motor up slightly, so motor brake is activated.

CAUTION

Do not over lower motor so slack develops in cable. Doing this could cause cable to jump off motor spool. This may result in sloppy wrapping of cable next time you raise the lift, resulting in premature wear or cable breaking.

REMOVAL & STORAGE (winterizing)

****The Feighner Company, Inc. does not warrant this product against any damage caused by or related to ice!!**

CAUTION

Ice can severely damage your boatlift. Do not leave lift, or boat on lift, in water if ice damage is possible.

#1 Be sure lift rack is in fully lowered position. This will prevent rack from pivoting when moving lift out of water.

CAUTION

A raised lift rack could cause a pinching or cutting injury during removal. Be sure lift rack is fully lowered when removing. Never move or carry your boat lift by grabbing the lift rack.

#2 Carry, lift, roll, float or slide lift out of water. Position safely away from potential ice build up.

SERVICE (Maintenance)

#1 Inspect nuts and bolts at least every six months for damage, wear or loose connections. Tighten or replace parts as needed.

CAUTION

Check cables for frays, corrosion or breaks at least once a month. A cable breaking while boat is in lift could damage boat or lift. Severe bodily injury could also occur.

#2 Inspect lift frame, pulleys, motor and pivot points at least every six months for unusual wear, damage or bent parts. Replace or repair as needed.

#3 At least every six months, check that the rack is level with the bottom frame of your lift. Cable stretching or settling of lift could require you to adjust nuts on I-bolts.

#4 Lubricate motor gear and cables at least every six months.

#5 Lubricate pulleys at least every six months. Check I-Bolts every six months to make sure they are not working themselves loose.

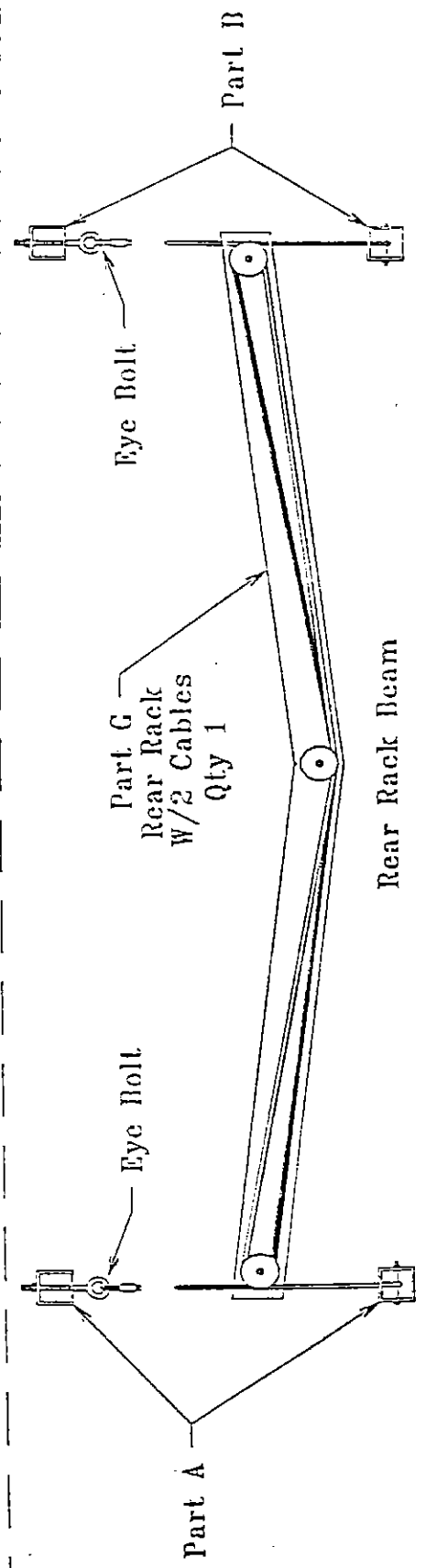
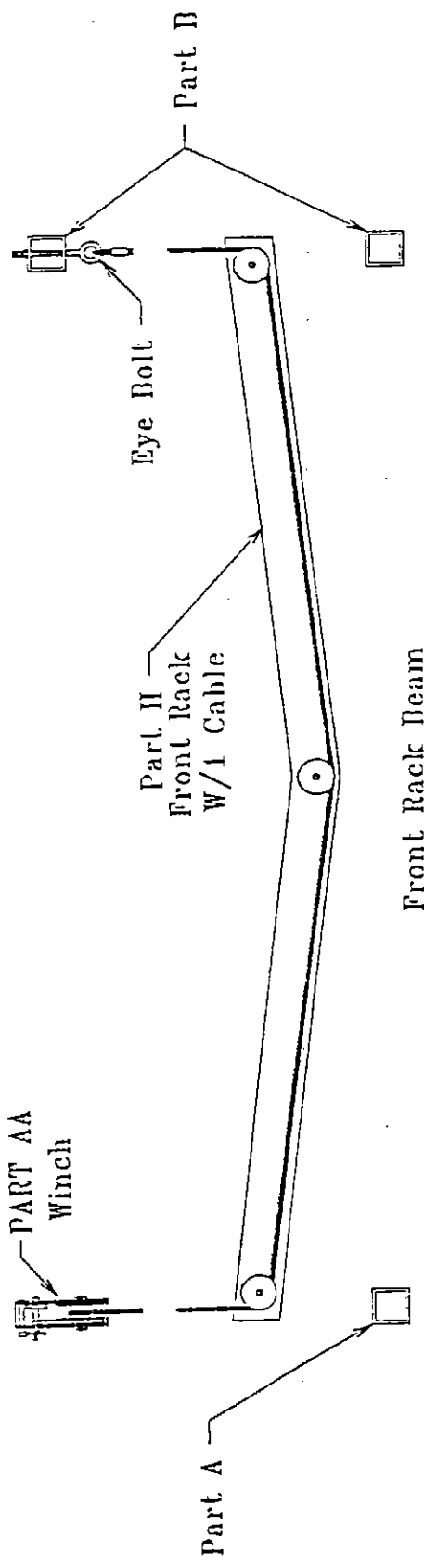
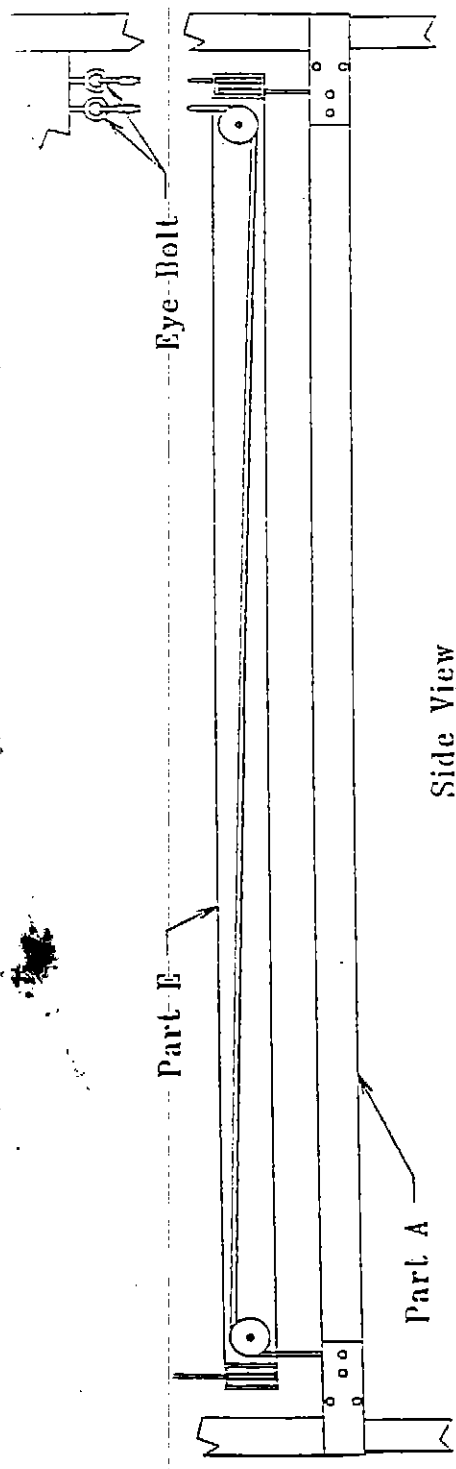

ELECTRIC POWER UNIT SAFETY

WARNING

1. Always turn off MAIN POWER SUPPLY when moving, swimming, or working on or around the lift.
2. It is recommended that power is shut off and/or motor unplugged when not in use to preserve the life of the motor. This will also prevent unauthorized use of the motor and lift.
3. Proper care should be exercised concerning wires, which are exposed to wave or wind oscillations. If wires are exposed, appear worn, or are weathered, turn off the MAIN POWER SUPPLY and get the unit repaired immediately. Kinks or breaks in wire could occur, resulting in **SERIOUS INJURY OR DEATH!!**
4. It is recommended that an electrician do installation and final inspection of this electric power unit. If at any time the unit is not operating properly, shut down the MAIN POWER SUPPLY and have it inspected by authorized service personnel.
5. NOT COMPLYING WITH THE ABOVE RECOMMENDATIONS MAY INVALIDATE THE WARRANTY OR RESULT IN PERSONAL INJURY OR DEATH.

*****GREASE MOTOR GEARS AT LEAST TWICE A YEAR!! PREFERABLY, EACH FALL BEFORE STORAGE AND EACH SPRING BEFORE USE*****

ELECTRIC POWER UNIT

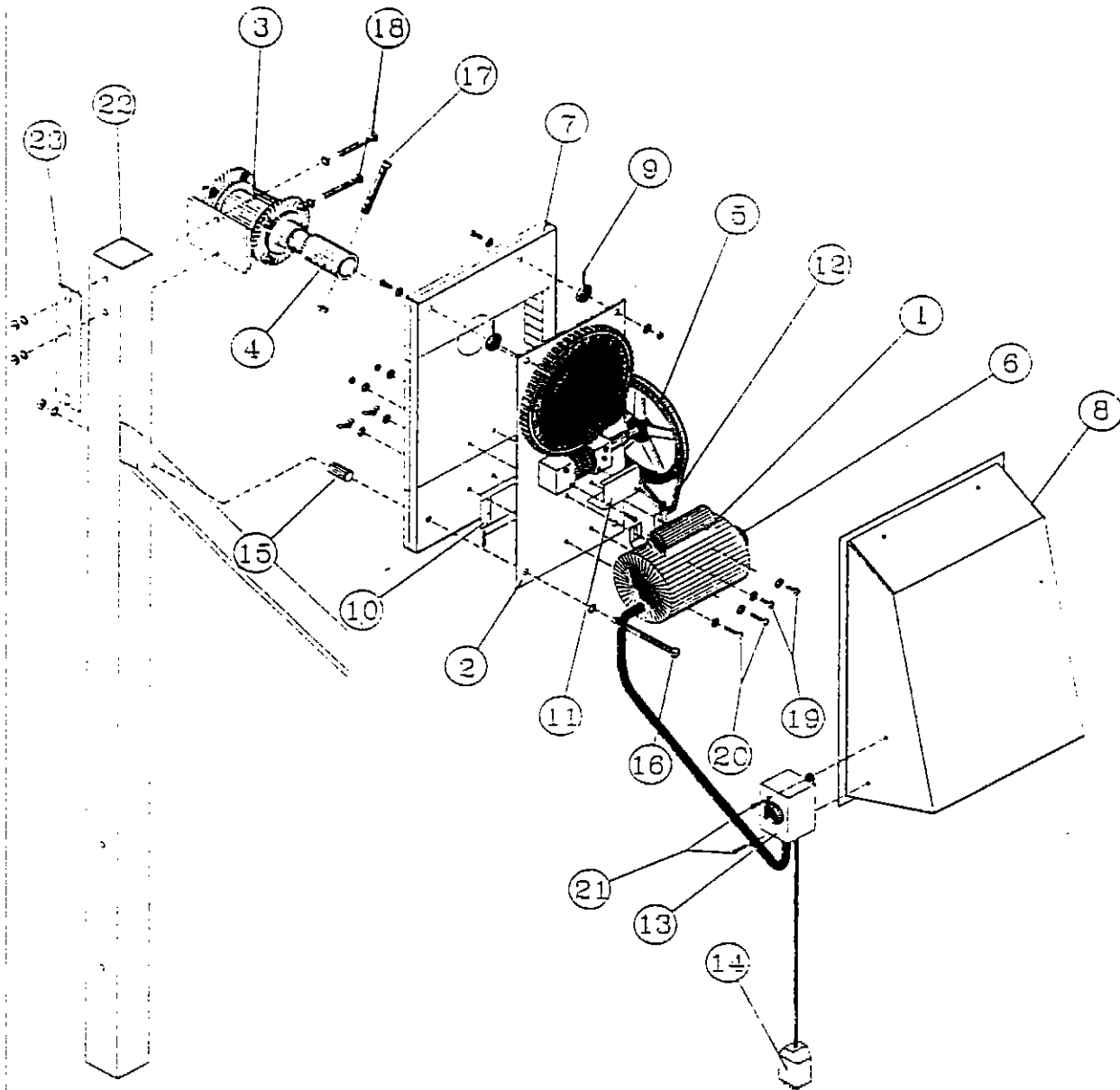

No.	DESCRIPTION
1	MOTOR
2	WORM GEAR ASSEMBLY
3	WINCH HUB
4	SPACER SLEEVE
5	LARGE PULLEY
6	SMALL PULLEY
7	BACK COVER
8	FRONT COVER
9	STEM
10	SLIDE PLATE
11	GREASE CUP
12	BELT
13	UP/DOWN SWITCH
14	GFCI
15	1-3/8" or 1-5/8" SPACER
16	3/8" x 7-1/2" or 8" MACHINE BOLT, (2) 3/8" WASHERS, (1) 3/8" NUT,
17	(1) 1/2" x 3-1/2" MACHINE BOLT, (1) 1/2" NUT,
18	(1) 1/2" x 4-1/2" MACHINE BOLT, (2) 1/2" WASHERS, (1) 1/2" NUT, (2 PLACES)
19	(1) 5/16" x 1" MACHINE BOLT, (2) 5/16" WASHERS, (1) 5/16" NUT, (2 PLACES)
20	(1) 5/16" x 1-1/2" MACHINE BOLT, (2) 5/16" WASHERS, (1) WING NUT, (2 PLACES)
21	(1) 1/4" x 1" MACHINE BOLT, (2) 1/4" S.S. WASHERS, (1) 1/4" S.S. NUT, (2 PLACES)
22	LIFT SIDE
23	WINCH SIDE

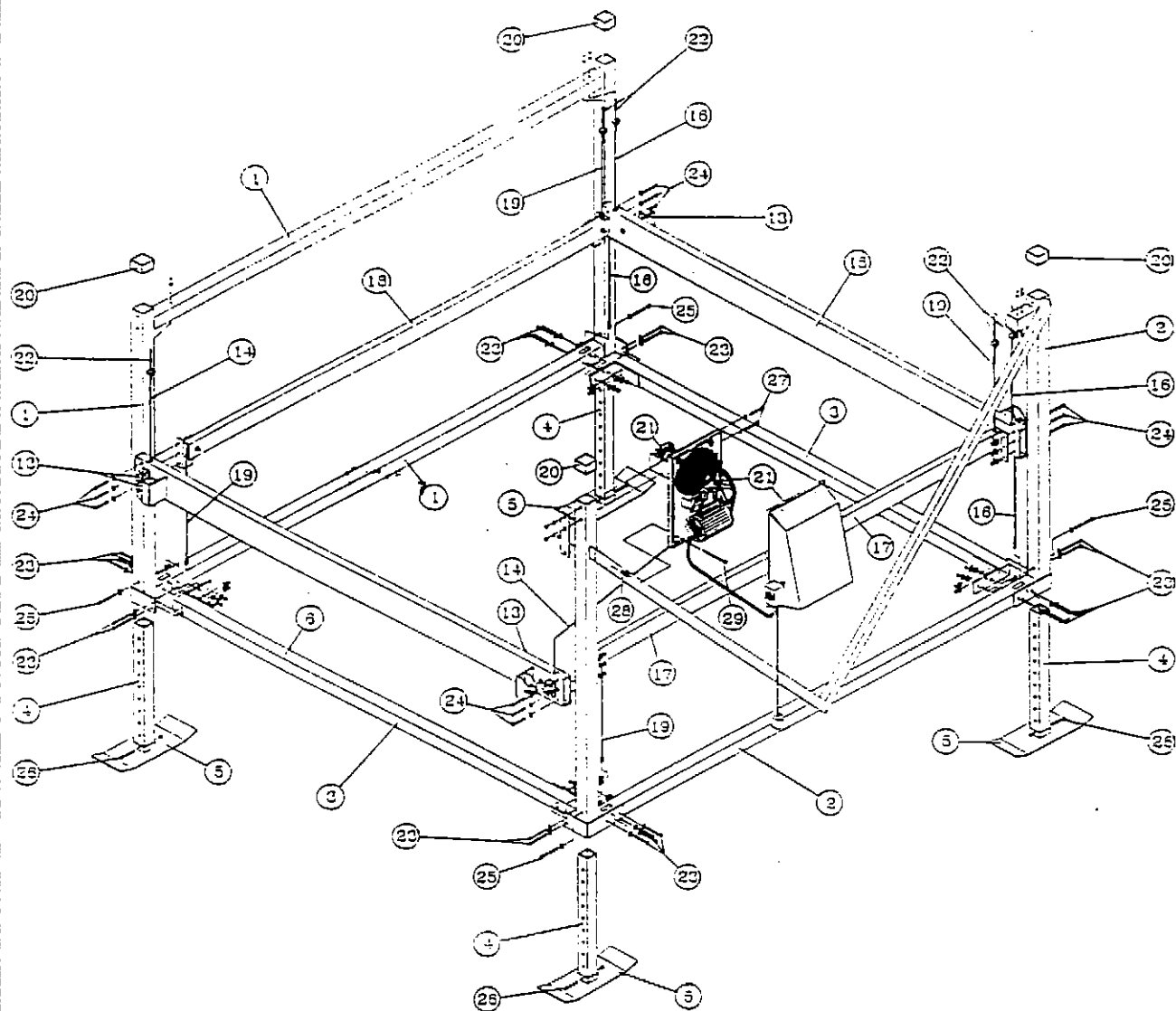

#	DESCRIPTION
1	OPPOSITE SIDE - 144.38", (1)
2	V-SIDE - 144.88", (1)
3	BOTTOM BEAM - 120", (2)
4	I-3 LEG POST - 36", (4)
5	I-3 LEG PAD, (4)
6	FRONT RACK BEAM ASSEMBLY COMPLETE - 130.5", (1)
13	ROLLER, (4)
14	5/16" x 24" STAINLESS STEEL CABLE COMPLETE, (FRONT RACK), (1)
15	REAR RACK BEAM ASSEMBLY COMPLETE - 130.5", (1)
16	5/16" x 198" STAINLESS STEEL CABLE COMPLETE, (REAR RACK), (2)
17	RACK SIDE ASSEMBLY COMPLETE - LEFT - 129", (1)
18	RACK SIDE ASSEMBLY COMPLETE - RIGHT - 129", (1)
19	5/16" x 203" STAINLESS STEEL CABLE ASSEMBLY, (SIDE RACK), (2)
20	#9 BLUE CAP, (4)
21	ELECTRIC WINCH, (1)
22	(1) 1/2" x 8" I-BOLT, (1) 1/2" WASHER, (1) 1/2" NYLOCK NUT, (5 PLACES)
23	(1) 1/2" x 5-1/2" MACHINE BOLT, (2) 1/2" WASHERS, (1) 1/2" NUT, (24 PLACES)
24	(1) 1/2" x 3-1/2" MACHINE BOLT, (2) 1/2" WASHERS, (1) 1/2" NUT, (12 PLACES)
25	(1) 1/2" x 4-1/2" MACHINE BOLT, (2) 1/2" WASHERS, (1) 1/2" NUT, (4 PLACES)
26	(1) 1/2" x 4" MACHINE BOLT, (1) 1/2" NUT, (4 PLACES)
27	(1) 1/2" x 5" MACHINE BOLT, (2) 1/2" WASHERS, (1) 1/2" NUT, (2 PLACES)
28	(1) 1-5/8" WINCH SPACER (1 PLACE)
29	(1) 3/8" x 3" MACHINE BOLT, (2) 3/8" WASHERS, (1) 3/8" NUT, (1 PLACE)